

ABERDEENSHIRE COUNCIL
PLANNING POLICY & ENVIRONMENT TEAM

Strichen Conservation Area Management Plan (2010)



Hamish Robertson, Environment Planner (North)
8th April 2010

Preservation of the Historic Environment

In regard to conservation areas, a local authority will; determine; designate; publish policies and proposals and exercise appropriate development management that together, will preserve or enhance its character or appearance.

“There is effectively a presumption in favour of preserving the character of an area once it has been designated”. – S64, Planning (Listed Building & Conservation Areas) (Scotland) Act 1997

The Strichen Conservation Area Management Plan rests within the Councils Historic Environment Strategy and Local Development Plan policies which will, with consistent and appropriate Development Management decisions, provide the basis for the continued protection and enhancement of this distinct and valuable historic environment.

General Principles

1. Community Engagement, Endorsement and Participation

The Council will promote the quality of the Conservation Area through education and active engagement with the community. Professional advisors and trades-persons engaged in development and the maintenance of historic buildings will be targeted towards improving its quality and the use of appropriate materials to properly conserve historic buildings.

Action

Environment Team (North) to raise awareness with owners and those engaged in property maintenance of the significance of the local historic environment and the need for appropriate craftsmanship and materials to be applied in its conservation and preservation. Develop a database, appropriate publications/communications and distribute advice making use of resources provided by Historic Scotland and centred in the Local Library.

2. Councillor Support

The Council will, in making decisions support the retention of Strichen Conservation Area; the protection and enhancement of its character.

Action

A report will be presented to the Buchan Area Committee to permit endorsement of the Strichen Conservation Area Management Plan (2010) as Planning Advice. Thereafter, Committee will strive to deliver consistent Development Management decisions appropriate to the protection and enhancement of Strichen Conservation Area.

3. A strong policy position set within the Local Development Plan

The Strichen Conservation Area Review (2009) will help interpret Council policy for the settlement contained within its adopted Local Development Plan. It will inform specific planning advice.

Action

Action to provide detailed planning guidance will include:

Developing Planning Policy and publishing a Detailed Guidance Note, consistent with emerging Local Plan Policy, advising on design and development that is sympathetic to the conservation area;

Developing Planning Policy and publishing a Detailed Guidance Note permitting some PVCu windows within the conservation area;

Developing Planning Policy and publishing a Detailed Guidance Note regarding inappropriate dormer windows, altered structural openings and styles of glazing;

Develop and publish information regarding the retention of character in buildings where there are multiple owners.

4. Informed and pro-active Development Management

The Strichen Conservation Area Review (2009) and supplementary planning guidance that follows from it will be relied upon by Development Management to promote development that protects and enhances its character.

Action

Action will be advanced at Planning & Environmental Services management levels to coordinate the effort of Planning Policy, Environment and Development Management Teams in order to properly respond to the protection and enhancement of Strichen Conservation Area and react to the findings of the Strichen Conservation Area Review (2009) and proposals set within the Historic Environment Strategy (2010) confirming Strichen as “the best of Aberdeenshire” regarding its historic environment.

Environment Team (North) will consult with Historic Scotland regarding Strichen’s Listed Buildings invite their re-survey and consideration of some buildings as being added to lists.

5. Necessary and appropriate enforcement

The Strichen Conservation Area Review (2009) confirms the need to exercise enforcement action to properly manage the Conservation Area. The Council confirms that it will take enforcement action to protect the historic environment and ensure that the quality of Strichen Conservation Area is not eroded.

Action

Environment Team (North) to liaise with Development Management to implement any necessary enforcement action to prevent the quality of Strichen Conservation Area being eroded.

6. Article 4 Directions

To prevent further erosion to the character and detail of Strichen Conservation Area through inappropriate “permitted development” such as the installation of some replacement windows, replacement doors or other works, the Council will advance Article 4 Directions to regain control over such development.

Action

Environment Team (North) to promote Article 4 Directions removing “permitted development rights”.

7. Conservation Area Boundary

The Council will promote a revised boundary to the Conservation Area through its Local Development Plan suggested by Detailed Guidance Note, DGS/6.

Action

Environment Team (North) notified the proposed boundary alteration to Policy Team on 8.3.10 requesting this be confirmed via the emerging Local Plan.

8. Design and Development Guidance

A Design/Development Brief will be prepared for the opportunity site at Market Stance. This follows a Committee decision on 15th September 2009 refusing full planning permission for a housing development, in part because it would “have an adverse impact upon the character and setting of the Conservation Area”.

Housing sites identified by the Local Development Plan to permit growth and requiring the preparation of a Master Plan will require to take full account of the Strichen Conservation Area Review (2009), Management Plan (2010) and the policies and guidance of the Council in relation to the preservation of the character and quality of Strichen Conservation Area and its landscape setting.

The Strichen Conservation Area Review (2009) also identified development within the lanes and erosion of their original character and quality as a matter of concern.

Action

Develop and publish a Design/Development Brief for Market Stance.

Environment Team (North) to advise and liaise with Policy Team and Development Management colleagues so that all Master Plans well relate to the preservation of the existing character of the conservation area.

Develop and publish Design Guidance for backland development accessed via historic lanes.

9. Strichen Town House

The Council will promote Strichen Town House as a major conservation and restoration demonstration project as a commitment to the historic environment in consultation with and to benefit the community.

Action

Environment Team (North) with colleagues from Education Leisure and Learning and assisted by Buchan Development Partnership will investigate a restoration and redevelopment project to secure the future of this A-Listed property to benefit the community.

10. Grant Scheme

The Council will explore the introduction of a scheme providing small grants to support the retention of architectural detail and historic character.

Action

Environment Team (North) will investigate opportunities to deliver a small grant scheme to support the proper maintenance and enhancement of historic buildings within the conservation area. Consideration will be given to using any planning gain contributions secured through new development to fund the scheme.

Detailed Planning Guidance

Some matters are covered in a suite of Planning Guidance Notes specific to Strichen Conservation Area and form part of its unique Conservation Area Management Plan (2010). These matters were identified by the Strichen Conservation Area Review (2009) as requiring detailed guidance.

Note: In developing Guidance Notes the opportunity to combine some matters into a single publication will be considered. The Buchan Area Committee will be invited to formally endorse these ahead of their publication at a future date (2010).

DGS/1

Detailed Guidance Note, consistent with emerging Local Plan Policy, advising on design and development that is sympathetic to the conservation area;

DGS/2

Detailed Guidance Note regarding inappropriate dormer windows, altered structural openings and styles of glazing

DGS/3

Detailed Guidance Note permitting some PVCu windows within the conservation area;

DGS/4

Detailed Guidance Note regarding the retention of character in buildings where there are multiple owners;

DGS/5

Design Guidance Note for backland development accessed via historic lanes.

DGS/6

Detailed Guidance Note indicating the proposed boundary alteration advised to Policy Team on 8.3. 2010 intended for confirmation via the emerging Local Plan.

DGS/7

Design/Development Brief for Market Stance;

Master Plans

Environment Team (North) will advise and liaise with the Planning Policy Team and Development Management colleagues so that all Master Plans well-relate to the preservation of the existing character of the conservation area. Thereafter, these developer produced plans will be approved and adopted by the Council to guide appropriate development.

Project Work**P/1**

Environment Team (North) with colleagues from Education Leisure and Learning and assisted by Buchan Development Partnership will investigate a restoration and redevelopment project to secure the future of this A-Listed property to benefit the community.

P/2

Environment Team (North) will investigate opportunities to deliver a small grant scheme to support the proper maintenance and enhancement of historic buildings within the conservation area. Consideration will be given to using any planning gain contributions secured through new development to fund the scheme.

DGS/3

Detailed Guidance for replacing windows in Strichen Conservation Area.

Most traditional windows of timber construction can be repaired and refurbished back into proper use or into an enhanced condition. Some existing timber sashes can be altered to accept double glazed units. By using traditional internal shutters or double windows heat loss and energy consumption can be reduced. Where the choice is made to replace an existing window then some windows and factory produced products are more successful than others in helping to retain a sense of original character.



Replacement PVCu double glazed windows in a variety of glazing patterns, opening styles, quality and finish. The property second from the left with the blue door is the most successful of these in retaining some resemblance to its original character.

The use of PVCu in preference to timber is generally recognised as unacceptable in any Conservation Area as it destroys original character apart from any separate consideration regarding sustainability. PVCu is not acceptable in the replacement of any window in a Listed Building. In buildings listed by Historic Scotland for their architectural or historic significance only the retention and repair of existing windows or the use of traditional materials and craftsmanship will be acceptable if replacement of a complete window is necessary.

Perhaps worse than the introduction of modern materials, usually accompanied by double glazed units, is a profusion of opening styles and the loss of original glazing patterns. These are replaced with windows in many differing glazed proportions often with small top hung opening sections. These detract from the character of individual buildings and quality of the entire Conservation Area.



The photograph on the left shows nine different glazing patterns over four properties. This clearly diminishes the overall character and unity of architectural components once evident in the Strichen Conservation Area.

This said, a clear outcome of the discussion of the Conservation Area Review with Elected Members and the community was the desire to allow PVCu as a widely available product option to be

accepted within the Conservation Area, regardless of its inherent failure to meet historical or sustainability criteria. Architecturally with the appliance of detailed guidance and control, a semblance of historical character can be maintained.

Products are available that reasonably replicate the proportions and style of traditional sliding sash and case windows and in non-listed properties within the Conservation Area these could be considered acceptable behind the preference of encouraging the repair, like-for-like replacement of hand crafted painted timber sliding sash and case windows, or new timber windows that replicate an original style but incorporate double glazed units.

Carefully specified PVCu products incorporating double glazed units within the sash frame will be accepted in unlisted historic buildings within Strichen Conservation Area and in new development that, as far as it is possible to do so, replicate traditional glazing patterns and opening styles. This said, the most appropriate and historically correct approach of installing timber sliding sash and case windows will always be encouraged ahead of any PVCu product that attempts to replicate this original, historic and sustainable craftsmanship.

In C – Listed Buildings where the full replacement of any traditional window is accepted then a window that replicates, as far as it is possible to do so, the original window in proportions, glazing pattern, opening style and detail, but which may be double glazed, will be accepted. The material used will be best quality red-pine pre-treated against wet rot with a paint finish. Astragals will read through the glazing, be part of the window construction and not planted onto double glazing units. The width of astragals should not exceed 30mm. Triangular glazing beads to mimic the traditional chamfered putty line must be used. Care must be taken to replicate any moulding apparent on original frames and sashes to recreate the true quality and level of craftsmanship previously displayed on the building. Spiral spring balances will be an acceptable alternative to a traditional cord and pulley raised sash. Care must be taken to complete the window with traditionally styled ironmongery, locking catch and pull rings.

This departure from replicating a traditional window in a true like-for-like basis in the original hand crafted way with single glazing recognises consumer demands for double glazing and action on concern for climate change, the need to reduce energy consumption and carbon dioxide emissions.

In all other buildings listed by Historic Scotland for their architectural or historic significance only the retention and repair of existing windows or the use of traditional materials and craftsmanship will be acceptable if replacement of a complete window is necessary.

Further Reference:

Features and typical detailing of sliding sash and case windows are well detailed in Historic Scotland publications referenced below. Local evidence of past practice, craftsmanship and detailing is perhaps more relevant in determining how to retain existing character, local identity and sense of place.

The following photographs 1 & 2 are examples of original painted timber sliding sash and case windows existing in Strichen at the time of the Conservation Area Review (2009).



1.



2.



3.

Replicating such character as an example needs detailed reference to: glazing pattern (a 2 over 2 arrangement of panes is shown above); sash proportions (the windows shown are split in 50/50 proportions); the width of timbers used in the frame of the sash, meeting and bottom rail, the width of the case projecting beyond the edge of the structural opening, whether horns are present (they are absent above) and the width of the central glazing bar or astragal. The window should also replicate any moulding and traditional window furniture (fastener and pull rings). The alternative spiral balance mechanism to that of the traditional weight, pulley and cord system will be acceptable on replacement windows in unlisted and C-Listed buildings.

Single glazing was traditionally held in place with sprigs and chamfered putty. Double glazed units require a bedding strip with triangular timber beads as shown in the 1:1 scale detail following.

Any PVCu product specification and detailing must be equally critical in order to avoid inappropriate and poor attempts at mimicking previous craftsmanship and quality in manufacture and detailing. Photograph 3 provides a poor quality and unacceptable offering as a PVCu sliding sash window. The 1 over 1, 60/40 glazing pattern may have replicated an original window pattern but the width of the framing used, poor quality construction and jointing process, including packing out beyond the structural opening, makes this a clumsy and poor quality replacement of any traditionally crafted window. Much better quality PVCu products are available and only the very best available can be considered for acceptance in substitution of traditionally crafted timber sliding sash and case windows.

Detail - read through astragal permitting installation of a double glazed unit.

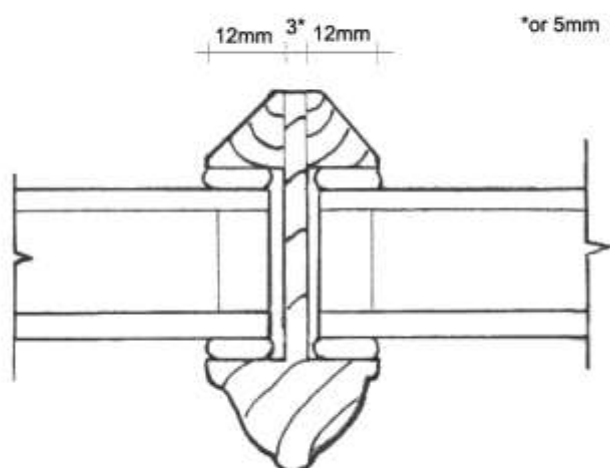

Fine bar "read through" astragal

Leading Manufacturers and Specialists

Aberdeenshire Council gives no recommendation as to the competence of any product, manufacturer or installer. It recognises the following companies as leading contenders in developing products and skills appropriate to the repair of traditional and replacement windows in the historic environment. Traditionally, local craftsmen supplied local needs and a few capable and specialist joinery and building firms will retain the capacity and skills to repair and replace traditional sliding sash and case windows. The choice of any contractor remains at the discretion of the property owner, agent, or professional advisor. What must inform this choice is in achieving the proper quality of workmanship, design and compatibility appropriate to any historic building or Conservation Area.

Referenced details:

Masterframe Windows Ltd. - Bygone Collection, manufacturer of sliding sash and case windows in either timber or PVCu. www.bygonecollection.co.uk Tel. 0800 591 854.

Brian Campbell's Joinery Workshop, Unit 1, Coalford Yard, Drumoak, AB31 5AR - manufacturer of timber sliding sash and case windows, email bcjw@fsmail.net, Tel.01224 739073

Ventrolla – specialist repairs and refurbishment of existing timber sliding sash and case windows and manufacturer of new timber windows. Installer of patented secondary glazing and draught proofing systems. www.ventrolla.co.uk Tel. 01576 202402

Sturrocks Joinery – manufacturer of sliding sash and case windows, www.sturrocksjoinery.com Tel. 01307 820209

Historic Scotland Advice and Publications

Looking after your sash and case windows – a short guide for homeowners
Inform – Maintaining sash and case windows

Note: publications are available directly from Historic Scotland, Longmore House, Edinburgh, EH91SH or as a free download from www.historic-scotland.gov.uk or from Strichen Public Library.

For Technical Guidance, Windows visit:
<http://www.historic-scotland.gov.uk/index/heritage/policy/managingchange.htm>

Environment Team (North) March 2010

Detailed Guidance Note, alteration to Strichen Conservation Area Boundary.



A mature boundary hedge and tree lined edge along Sleigh Crescent appears a more logical boundary for the Conservation Area. The suggested boundary change was discussed with the public as part of a review of the Conservation Area in 2009 and at a following public meeting on its findings in January 2010. This proposal was advised to the Council's Planning Policy Team on the 8th March 2010 for confirmation through the Local Development Plan.

Proposed boundary



Existing Boundary: 

Proposed boundary change: 